

BLOC MARCHES

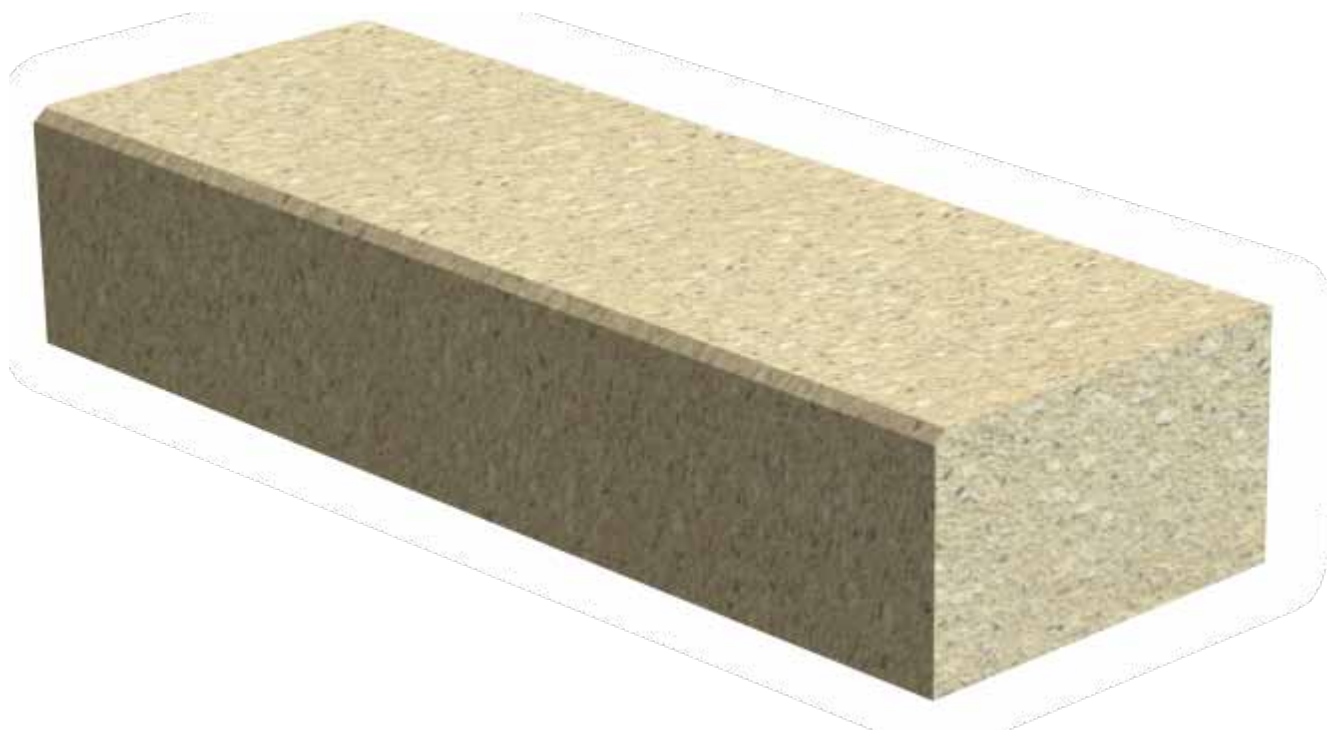

myway.®

BLOC MARCHES

Caractéristiques

L cm	l cm	h cm	Poids Kg/u
100	30	20	144
	35	20	168
	40	15	144
	40	17	163
	40	20	192

Conditionnement

A l'unité sur palette perdue en bois
Élément monobloc

Installation : par scellement au mortier ou collage

Manutention par chariot élévateur et transpalette

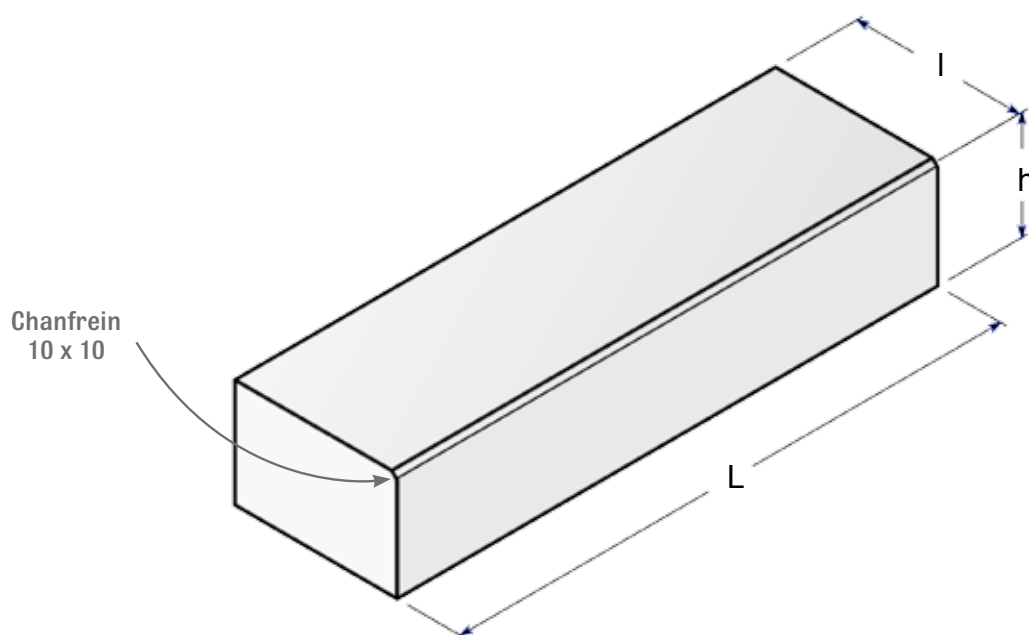

Parement

Gris Sablé



Gris anthracite
Sablé



Ocre Sablé



Blanc Sablé



Jennifer Fradin

Responsable département
environnement

Tel : 04 70 48 56 46

Jenniferfradin@prefac.com

Le Port Canal - BP 30
03290 Dompierre sur Besbre

Tél. 04 70 48 56 40

Fax. 04 70 34 55 75
info@prefac.com

www.prefac.com